



MEGASEW
Industrial sewing machine

MJ101TX

The one beyond the best



MJ101TX



台灣名匠













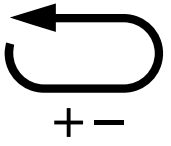
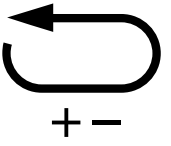
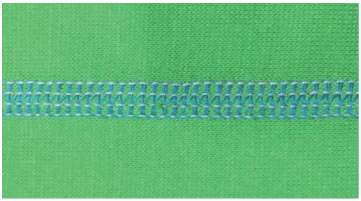

Patent Protection
多國專利，仿冒必究

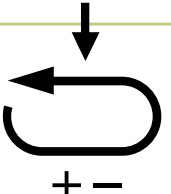
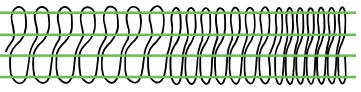
01 Advanced Innovation Design – “Triple Differential Ratio Feeding” to make the sewing even and flat more easily

三差動創新設計，輕鬆實現縫製均勻及平整度

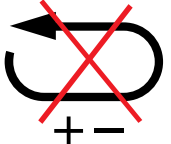
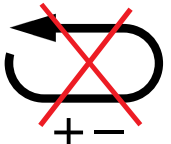
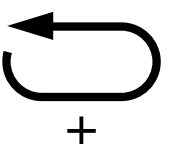

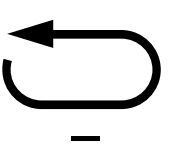
Characteristics Of TRIPLE Differential Ratio Feeding / 三差動特點

 <p>1</p>	 <p>2</p>	 <p>1</p>	<p>Flexible Knit Fabrics 彈性針織布</p>
	 <p>+ -</p>	 <p>+ -</p>	
 <p>3</p> <p>2</p> <p>TRIPLE Diff. 三差動</p>	 <p>3</p>	 <p>+</p>	<p>SPI Adjustment 粗細針調整</p>
	 <p>+ -</p>		
 <p>1</p> <p>SINGLE Diff. 單差動</p>	 <p>1</p>	 <p>1</p>	<p>Flexible Knit Fabrics 彈性針織布</p>
 <p>+ -</p>	 <p>+ -</p>	 <p>+</p>	
		 <p>-</p>	

02 Ergonomic Design to get a wider sewing view for seaming and to sit straight up easily without tilting body and head 藉由人因工程取得更寬廣縫製視角，自然坐姿無需傾身扭頭即可輕易檢視及車縫

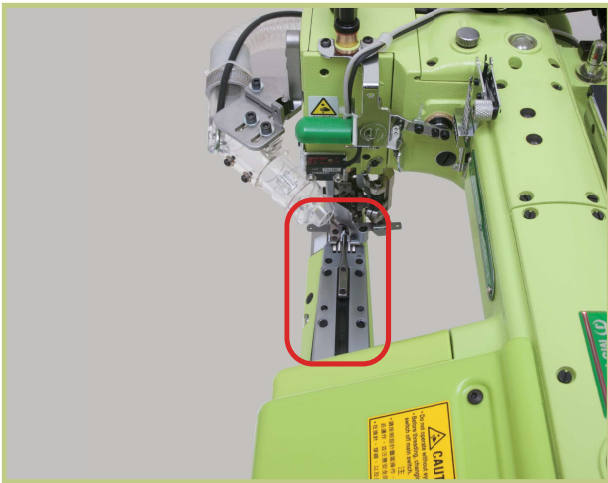

03 Innovative external Bottom Thread Cam to solve thread jam and to make threading, adjusting, cleaning and maintaining easier 底線凸輪外移之便捷設計，解決卡線問題並提高穿線、調整、清理、維護之方便性!



04 Moveable Front Needle Guard to prevent needles or retainer from breaking 直進式可調整前擋針片，既能保護縫針又能避免假針損壞

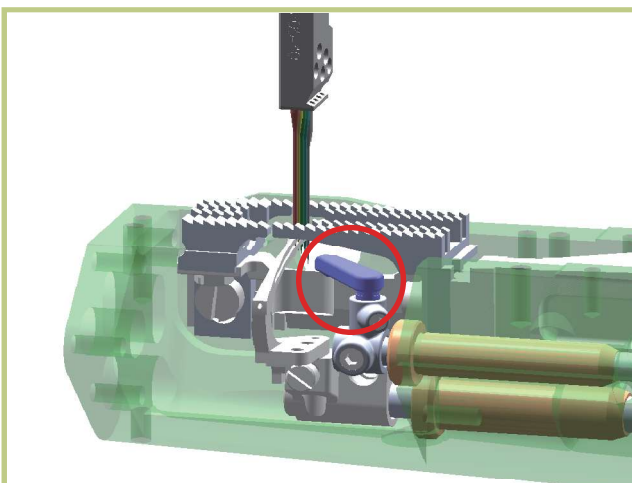

05 SCD-Unprecedented Stitch Condenser for Flat Seaming Machine to prevent the thread ends from breaking up before lapping and jointing the next step
 SCD裝置具線尾密縫功能，於下道工序併縫時避免脫線

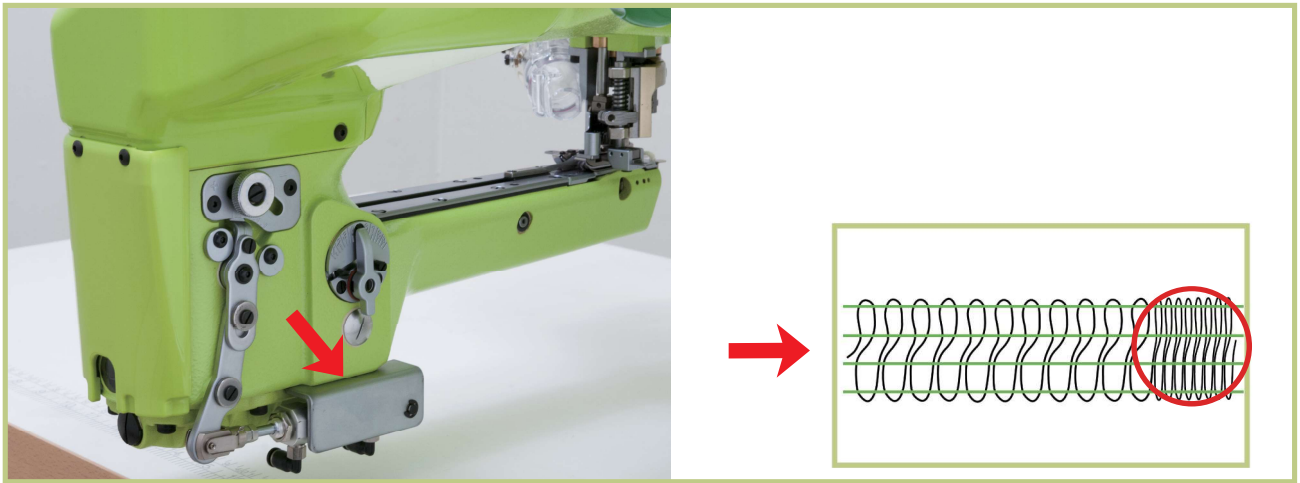

MJ101TX-452(460)-05/DSV/AT/AW

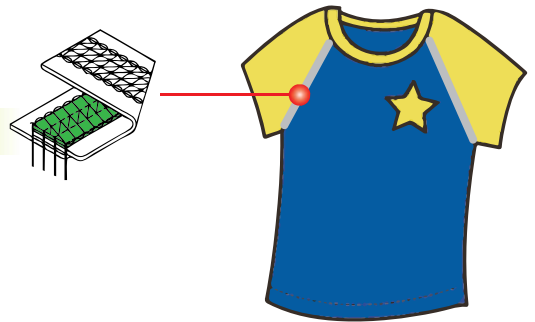

MJ101TX-452(460)-02H2/DSV/AT/AW

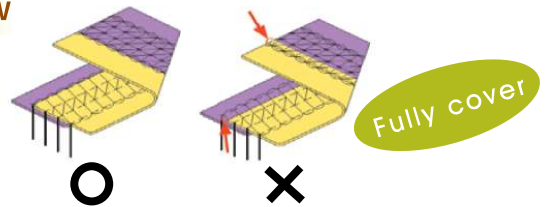

MJ101TX-452(460)-03(04)/DSV/AT/AW

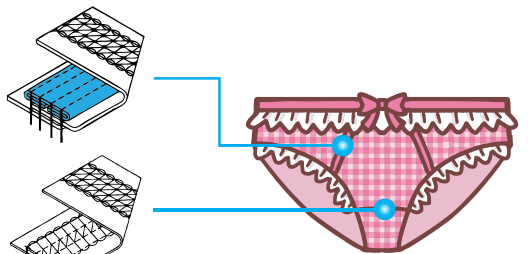

MJ101TX-452(460)-01/DSV/AT/AW

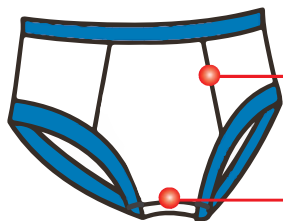
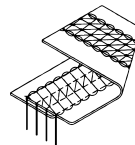





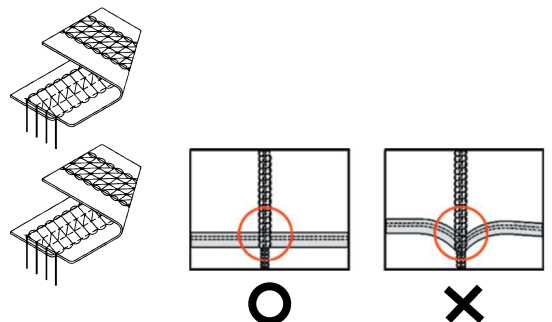



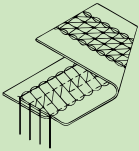
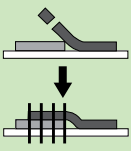

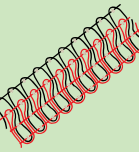
MJ101TX-452(460)-02/DSV/AT/AW

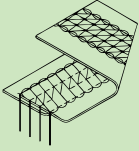
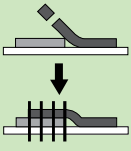
MJ101TX-452(460)-02H1/DSV/AT/AW

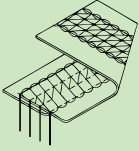
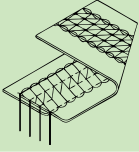
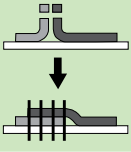
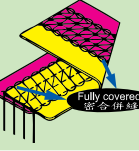
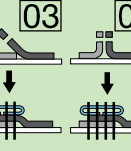

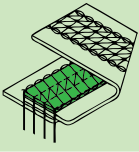
Applications

			MJ101TX-452(460)- 01 (01S) Standard 4 Needle Flatseamer for Light to Medium Material and Pantihose. 四針六線併縫車，適合薄到中厚布料及連褲襪。
			MJ101TX-452(460)- 01/DCC 4 Needle Flatseamer for Light to Medium Material with Double Colored Cover-stitching. 四針六線併縫車，適合薄到中厚布料。上飾線雙色打網。
			MJ101TX-452(460)- 01H 4 Needle Flatseamer for Heavy Material and Diving Suit. 四針六線併縫車，適合厚布料及潛水衣。
			MJ101TX-452(460)- 02 Standard 4 Needle Flatseamer for Light to Medium Material. 四針六線併縫車，適合薄到中厚布料。
			MJ101TX-452(460)- 02H 4 Needle Flatseamer for Heavy Material and Crossing Seams, with 1.5mm Stepped Presser Foot, Needle Plate. 四針六線，適合厚布及過骨。1.5mm 階梯式壓腳、針板。
			MJ101TX-452(460)- 02H1 4 Needle Flatseamer for Crotch Seaming of Men's Briefs and Heavy Material. 四針六線併縫車，適合男用內褲褲底過骨併縫及厚料。
			MJ101TX-452(460)- 02H2 4 Needle Flatseamer for Fully Covering of the Seams. 四針六線，適合雙色布料完全密合併縫。
			MJ101TX-452(460)- 02H1+H2 4 Needle Flatseamer for Crotch Seaming of Men's Briefs + Fully Covering of the Seams. 四針六線，適合男用內褲褲底過骨併縫+完全密合併縫。
			MJ101TX-452(460)- 03 (04) 4 Needle Flatseamer ,One (Both) Side Fabric Trimmer,for Folded Taping. 四針六線併縫車、單(雙)切布，適合貼條併縫。
			MJ101TX-452(460)- 05 4 Needle Flatseamer for Reinforced Taping. 四針六線併縫車，適合貼條補強帶併縫。
			MJ101TX-452(460)- 06 (06A) 4 Needle Flatseamer for Unfolded (Folded) Piping. 四針六線併縫車, 適合無折邊(有折邊)飾條併縫。

MJ101TX

4 52 - 01 / DSV / AT / AW / TK1

Model 機種	
101	Ultra high speed flatseamer (No tilting) 超高速併縫車(免歪頭)
TX	Triple differential ratio feeding 三差動系列









Needle numbers 針數	
4	4 needles 4 針

Needle gauge 針寬	
48	Width 4.8 mm 寬4.8mm ※
52	Width 5.2 mm 寬5.2mm
60	Width 6.0 mm 寬6.0mm

Sewing function 縫製功能	
01	One side fabric trimmer 切單布併縫裝置
01S	One side fabric trimmer, for sewing pantyhose, leggings 切單布, 適連褲襪, 保暖襪等併縫裝置
DCC	One side fabric trimmer, 2-color cover stitching 切單布, 上飾線雙色打網併縫裝置
01H	One side fabric trimmer, for diving suit 切單布, 適厚料及潛水衣併縫裝置
02	Both side fabric trimmer 切雙布併縫裝置
02H	Both side fabric trimmer, 1.5mm stepped presser foot, needle plate, feed dogs, for heavy material 切雙布, 1.5mm階梯式壓腳、針板、送料具、適厚料併縫裝置
02H1	Both side fabric trimmer, for cross seaming 切雙布, 適男內褲或交叉過骨目併縫裝置
02H2	Both side fabric trimmer, for fully covered seam 切雙布, 適雙色布完全密合併縫裝置
03	One side fabric trimmer, for folded taping 切單布, 適貼條併縫裝置
04	Both side fabric trimmer, for folded taping 切雙布, 適貼條併縫裝置
05	Both side fabric trimmer, for reinforced taping 切雙布, 適補強帶併縫裝置
06	One side fabric trimmer, for unfolded taping 切單布, 適無折邊飾條併縫裝置
06A	One side fabric trimmer, for folded taping 切單布, 適有折邊飾條併縫裝置

Type of motor 馬達類型	
DSV	Direct Drive computerized mini servo motor 直驅式電腦伺服小馬達

Attachment 輔助件	
AT	Air type lifter 氣動抬壓腳
ET	Electric type lifter 電動抬壓腳
AW	Automatic waste suction set 自動吸布屑裝置
TK1	Air chop-type chain cutter 氣動式切線裝置
TK3	Pneumatic chain and tape cutter 氣動式切線及切帶裝置
SCD	Stitch condenser 結尾密縫裝置
L6	Top-feed rear puller 上送後拖輪

							
4	6	4.8 5.2 6.0	1.6 ↔ 2.5	1:0.5 ↔ 1:2.5(1:1.8)	6(8)	FLX118GCSX4#11 (#14)	4000

※ 4.8 : Special needle, please contact local agent or original manufacturer for service.
4.8 : 特殊針, 請洽當地代理商或原廠採購。

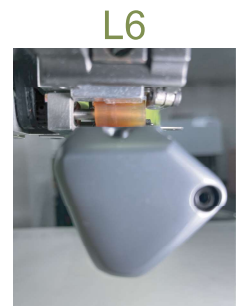

MING JANG SEWING MACHINE CO., LTD.
名匠縫紉機股份有限公司

 TAIWAN
EXCELLENCE 2010

 TAIWAN
INNOVATION AWARD



Visit us at : <http://www.ming-jang.com>
Contact us at : service@ming-jang.com

www.megasew.com

The specification and/or appearances of the equipment described in the catalogue are subject to change without previous notice because of modification.
由於產品的改進及更新, 本目錄中的規格及外觀修改恕不事先通知。

2025-03